



111-1.28

► **Description**

Exposed, Battery Powered, Sensor Activated, Royal® Optima® SMOOTH™ Water Closet Flushometer for floor mounted or wall hung top spud bowls.

► **Flush Cycle**

Model 111-1.28 High Efficiency (1.28 gpf/4.8 Lpf)

► **Specifications**

Quiet, Exposed, Diaphragm Type, Chrome Plated Closet Flushometer with the following features:

Flushometer

- PERMEX™ Synthetic Rubber Diaphragm with Dual Filtered Fixed Bypass
- ADA Compliant Metal Oscillating Non-Hold-Open Handle with Triple Seal Handle Packing
- 1" I.P.S. Screwdriver Bak-Chek™ Angle Stop
- Free Spinning Vandal Resistant Stop Cap
- Adjustable Tailpiece
- High Back Pressure Vacuum Breaker Flush Connection with One-piece Bottom Hex Coupling Nut
- Spud Coupling and Flange for 1½" Top Spud
- Sweat Solder Adapter w/Cover Tube and Cast Wall Flange w/Set Screw
- High Copper, Low Zinc Brass Castings for Dezincification Resistance
- Non-Hold-Open Handle, Fixed Metering Bypass and No External Volume Adjustment to Ensure Water Conservation
- Flush Accuracy Controlled by CID™ Technology
- Diaphragm, Handle Packing, Stop Seat and Vacuum Breaker molded from PERMEX™ Rubber Compound for Chloramine Resistance

Optima SMOOTH Unit

- ADA Compliant OPTIMA® SMOOTH™ Battery Powered Infrared Sensor for automatic "Hands-free" operation
- Sensor with Automatic Range Adjustment
- Chrome Plated Metal Sensor Housing
- Mechanical Manual Override Flush Handle
- Four (4) Size C Batteries included
- "Low Battery" Flashing LED
- "User in View" Flashing LED
- 25 to 80 psi Operating Range

Valve Body, Cover, Tailpiece and Control Stop shall be in conformance with ASTM Alloy Classification for Semi-Red Brass. Valve shall be in compliance to the applicable sections of ASSE 1037.

► **Variations**

- YG** Extended Bumper on Angle Stop (for seat with cover)

Fixtures

- Consult Sloan for Sloan brand matching fixture options.

HET
 HIGH-EFFICIENCY TOILET



► **ADA Compliant**

► **Automatic**

Sloan SMOOTH™ equipped Flushometers provide the ultimate in sanitary protection and automatic operation. There is no need for AC hookups or wall alterations. The Flushometer operates by means of a battery powered infrared sensor. Once the user enters the sensor's effective range and then steps away, the SMOOTH™ Unit initiates the flushing cycle to flush the fixture. State-of-the-art Technology enables activation of a manual override without "double flushing" occurring as the user departs (locks out sensor for approximately 10 seconds).

► **Hygienic**

The Royal® Optima® SMOOTH™ Flushometer is the next advancement in hygiene. It uses sensor technology to transform manual installations into electronic, hands-free operation. User makes no physical contact with the Flushometer surface except to initiate the Override Handle when required. Helps control the spread of infectious diseases.

► **Economical**

Automatic operation provides water usage savings over other flushing devices. Reduces maintenance and operation costs. Installation and battery replacement does not require turning off water to the valve.

► **Warranty**

3 year (limited)

| | |
|--|----------------|
| This space for Architect/Engineer approval | |
| Job Name _____ | Date _____ |
| Model Specified _____ | Quantity _____ |
| Variations Specified _____ | |
| Customer/Wholesaler _____ | |
| Contractor _____ | |
| Architect _____ | |



Sloan Valve Company is buying renewable energy certificates to meet 100% of the company's purchased electricity use at its Franklin Park, Illinois facility.

111-1.28



- ▶ **Description**
Exposed, Battery Powered, Sensor Activated, Royal® Optima® SMOOTH™ Water Closet Flushometer for floor mounted or wall hung top spud bowls.
- ▶ **Flush Cycle**
Model 111-1.28 High Efficiency (1.28 gpf/4.8 Lpf)

ELECTRICAL SPECIFICATIONS

- ▶ **Control Circuit**
6 VDC Input
- ▶ **OPTIMA Sensor Type**
Active Infrared with Automatic Adjustment
- ▶ **OPTIMA Sensor Range**
Normal Range:
26" - 32" (660 mm-813 mm)
Reduced Range:
20" - 26" (508 mm-660 mm)
- ▶ **Battery Type**
(4) Size C Alkaline
- ▶ **Battery Life**
2 Years @ 4,000 Flushes/Month
- ▶ **Indicator Lights**
User in View/Low Battery
- ▶ **Operating Pressure**
25-80 psi (172-552 kPa)

OPERATION

1. A continuous, invisible light beam is emitted from the SMOOTH unit's Infrared Sensor.
2. When the user enters the sensor's effective range, the Red LED light in the sensor window flashes for eight seconds. After eight seconds of sensing the user, the light will stop flashing and the unit waits for the user to step away before initiating a flush cycle.
3. When the user steps away, the unit initiates a flush cycle. The unit then automatically resets and is ready for the next user.

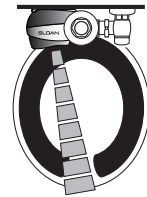
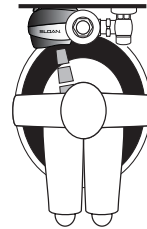

DIMENSIONS

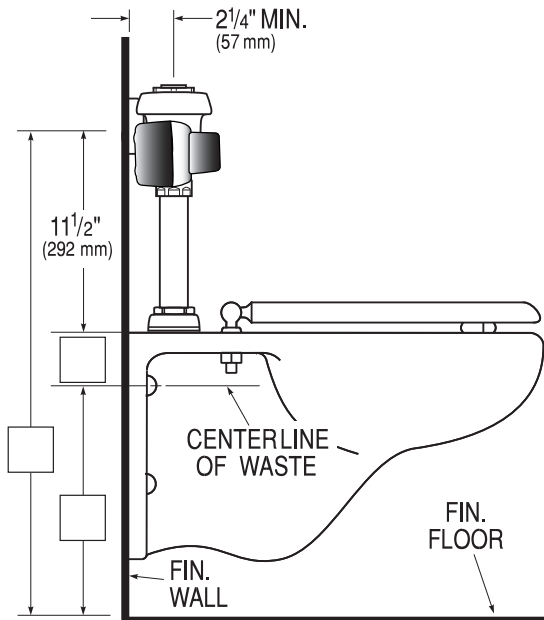

Side View

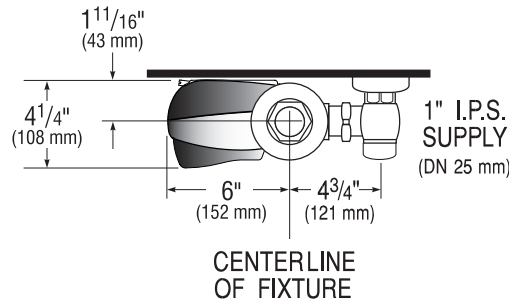

Top View

SLOAN VALVE COMPANY • 10500 SEYMOUR AVENUE • FRANKLIN PARK, IL 60131

Phone: 1-800-9-VALVE-9 or 1-847-671-4300 • Fax: 1-800-447-8329 or 1-847-671-4380 • www.sloanvalve.com